

VISCOELASTICITY WITH AGING CAUSED BY SOLIDIFICATION OF NONAGING CONSTITUENT

By Ignacio Carol,¹ Associate Member, ASCE, and Zdeněk P. Bažant,² Fellow, ASCE

ABSTRACT: The classical viscoelastic models for aging materials such as concrete, which consist of Volterra history-integral equations, found only limited applications since they required storing the entire stress or strain history. Although the subsequent introduction of the Dirichlet series expansion of the creep or relaxation function reduces these requirements by leading to a set of linear differential equations equivalent to aging Kelvin or Maxwell chain models, problems arose in the identification of the aging moduli of these models. This paper refines and extends a recent formulation that remedies these problems by considering the aging to result from the progressive solidification of a basic constituent that behaves as a nonaging viscoelastic material. The new possibilities explored involve the alternative use of the relaxation function for characterizing the nonaging constituent, and the expansion of both the compliance and relaxation functions of the constituent into Dirichlet series. In this way, one recovers the rate-type equations of an aging Kelvin or Maxwell chain in which all the moduli vary proportionally to a single aging function $v(t)$. Some convenient advantages are the well-posedness of the problem of moduli identification, with always positive values, and the nonexistence of creep or relaxation reversal upon load removal.

INTRODUCTION

In the classical linear treatment of viscoelasticity of aging materials such as Portland cement and concrete (Maslov 1940; McHenry 1943; Arutyunian 1952), the material has been characterized by the compliance function $J(t, t')$ or the relaxation function $R(t, t')$. $J(t, t')$ represents the strain at time t caused by a unit stress step applied at time t' [Fig. 1(a)], and $R(t, t')$ represents the stress at time t caused by a unit strain step applied at time t' [Fig. 1(b)]. The times t and t' represent the age of the material. For values of the load step $\Delta\sigma$ or strain step $\Delta\varepsilon$ not equal to 1, the corresponding strain or stress history is $\varepsilon(t) = \Delta\sigma J(t, t')$ or $\sigma(t) = \Delta\varepsilon R(t, t')$. For the particular case $t = t'$, we have $J(t', t') = 1/E(t')$ or $R(t', t') = E(t')$, where $E(t')$ is the elastic modulus at age t' . In concrete, E increases with age as a result of chemical reactions of cement hydration. For the same reason, the rate of creep (delayed strain) or stress relaxation at the same $t - t'$ diminish with t' [Figs. 1(a), and (b)].

Assuming the principle of superposition, one obtains the classical Volterra integral equations:

$$\varepsilon(t) = \int_{t'=0}^t J(t, t') d\sigma(t') \dots\dots\dots (1a)$$

or

¹Assoc. Prof., Dept. of Civ. Engrg., ETSECCPB, Tech. Univ. of Catalonia, E-08034 Barcelona, Spain.

²Walter P. Murphy Prof. of Civ. Engrg., Northwestern Univ., Evanston, IL 60208.

Note. Discussion open until April 1, 1994. To extend the closing date one month, a written request must be filed with the ASCE Manager of Journals. The manuscript for this paper was submitted for review and possible publication on April 24, 1992. This paper is part of the *Journal of Engineering Mechanics*, Vol. 119, No. 11, November, 1993. ©ASCE, ISSN 0733-9399/93/0011-2252/\$1.00 + \$.15 per page. Paper No. 3961.

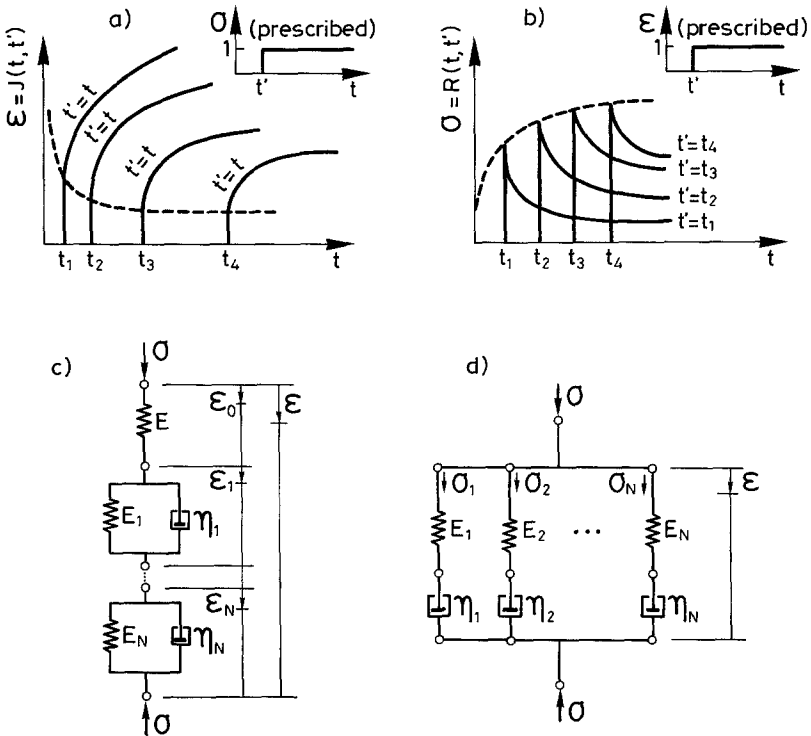

FIG. 1. (a) Loading History and Typical Curves for Various Values of Age at Loading t' of Compliance Function $J(t, t')$; (b) Same for Relaxation Function $R(t, t')$; (c) Kelvin Chain Rheologic Model; and (d) Maxwell Chain Rheologic Model

$$\sigma(t) = \int_{t'=0}^t R(t, t') d\epsilon(t') \dots\dots\dots (1b)$$

where the integral has the meaning of a Stieltjes integral, allowing for discontinuous (piecewise continuous) stress or strain histories with finite jumps (or steps) of $\sigma(t')$ or $\epsilon(t')$. The integral formulation given by (1a) or (1b) is one way to define the constitutive equation of aging linear viscoelasticity. It can be used directly in calculations when one knows a priori the history of either the prescribed stress or strain. However, it is not well suited for general numerical computations, for which the time is usually discretized by finite increments $\Delta t_r, r = 1, \dots, N$, and the integral is approximated by a sum. Eq. (1) thus takes the form of algebraic relations which can be treated as quasi-elastic constitutive equations, relating the increments $\Delta\sigma_r$ and $\Delta\epsilon_r$ for interval Δt_r . Evidently, the calculation of the r th increment of stress from strains (or vice versa for the equation based on R), requires a summation over all the previous time steps $k = 1, \dots, r - 1$. That is a serious disadvantage since, for a large structural system, the necessary computer storage space and the computer time become very large.

As a remedy, it soon became apparent—first for nonaging viscoelasticity (Zienkiewicz et al. 1968; Taylor et al. 1970) and then for aging viscoelasticity (Bažant 1971; Mukaddam 1974; Kabir and Scordelis 1979)—that, by ex-

pressing the creep or relaxation functions as a sum of exponentials (i.e., Dirichlet series), it is possible to convert the integral (1) into a set of linear differential equations, which turn out to be the governing equations of the well-known Kelvin or Maxwell chain rheologic models with aging spring moduli $E_{\mu}(t)$ and dashpot viscosities $\eta_{\mu}(t)$ [Figs. 1(c) and 1(d)]. These functions can be identified with the coefficients of the Dirichlet series expansion of J or R . The numerical solution then requires the storage and update of only a fixed and relatively low number of variables.

Although the use of this second approach overcomes the problem of computer storage and time, additional difficulties remain with the determination of the aging material parameters. Some useful procedures, based on an a priori choice of the number of terms N and of the retardation or relaxation times τ_{μ} , and then least-square determination of parameters $E_{\mu}(t)$ from the given creep data, have been proposed and successfully applied in practice (Bažant 1982b). There is, however, one basic problem associated with ill-posedness of the Dirichlet series expansion (Lánczos 1964). Small variations in the creep data can cause large variations in the resulting functions $E_{\mu}(t)$, and rather different sets of functions $E_{\mu}(t)$ can closely approximate the same $J(t, t')$. Due to this ambiguity, some of the functions $E_{\mu}(t)$ obtained in this way can take negative values for certain short time intervals, although the overall modulus of the chain is always positive and monotonically increasing. This can still give acceptable numerical results in the overall sense, but does not seem reasonable and thermodynamically admissible from the theoretical viewpoint.

Another interesting point can be mentioned with regard to the aging. For nonaging moduli E_{μ} , it has been demonstrated (Roscoe 1950) that, as the number of units in the chain (or, which is the same, the number of terms in the Dirichlet expansion) increases, both the Kelvin and Maxwell chain models converge to the same solution, i.e., they both can approximate any given compliance function with any desired accuracy. This is appealing since both the J and R approaches are two alternative descriptions of the same intrinsic phenomenon, which must give equivalent results, and it also means that other rheologic models need not be studied. However, these properties have not yet been analytically proven for the case of aging, although numerical experience points to an affirmative answer.

In view of these problems, it is attractive to consider aging as the result of a progressive solidification of a basic constituent with intrinsically nonaging behavior, as proposed by Bažant (1977). Nonaging constitutive models can then be used for modeling the viscoelastic behavior of the constituent, thus avoiding the aforementioned difficulties, and all the aging effects are restricted to the description of the evolution of the solidification process itself [see Bažant and Prasanna (1989), based on the previous idea (Bažant 1977, 1979) of a solidification model with parallel coupling of the newly solidified layers and with a solidification function $v(t)$ representing the volume fraction of solidified material at age t]. In those works, a compliance function $\Phi(t - t')$ (or microcompliance function, as a function of one variable, $t - t'$), was assumed for the constituent, and an integral expression was obtained for the strain rate of the macroscopic solidifying material in terms of the derivatives of Φ and the function $v(t)$.

In the present work, new possibilities are investigated and a completion of the theory is attempted. As an alternative to Φ , a nonaging relaxation function $\Psi(t - t')$ or microrelaxation function is also used for representing the behavior of the solidifying constituent, and Dirichlet series expansions

are introduced for both the Φ and Ψ functions. Comparison of the resulting equations with the classical aging Kelvin or Maxwell chains provides new insight into the meaning of the solidification parameter $v(t)$. The result is a new, more general theoretical framework for aging viscoelasticity of materials such as concrete.

DIRICHLET EXPANSION OF COMPLIANCE AND RELAXATION FUNCTIONS AND EQUIVALENT RHEOLOGIC MODELS

As mentioned before, by choosing a Dirichlet series-type expression for the compliance or relaxation functions J or R , the integral equation (1) can be converted into systems of differential equations which are much more efficient for the numerical solution. A derivation of this theory for the case of aging material was given by Bažant (1971), elaborated on by Bažant and Wu (1973, 1974a, 1974b) and Bažant (1975, 1982a). The general derivation can be found in *Mathematical* (1988). Only the main assumptions and equations of the theory, together with some remarks relevant to the subsequent derivations, are outlined in this section. The general expression for $J(t, t')$ is (*Mathematical* 1988):

$$J(t, t') = \frac{1}{E(t')} + \sum_{\mu=1}^N \frac{1}{C_{\mu}(t')} \{1 - e^{-[y_{\mu}(t) - y_{\mu}(t')]}\} \dots\dots\dots (2)$$

where $y_{\mu}(t)$ = some monotonically increasing functions of time. A simple and convenient choice is $y_{\mu}(t) = t/\theta_{\mu}$ with θ_{μ} = constants called the retardation times, which must be suitably chosen with a not too large spacing in the log θ_{μ} scale. Eq. (2) should not be regarded as the “true” expression of the function $J(t, t')$, but rather as its Dirichlet series expansion, the true compliance function being defined either by a table of experimental data or better by some formula arising from physical considerations. In the literature, the term for instantaneous deformation $1/E(t')$ is often omitted in (2) because it is considered included as the first term ($\mu = 0$) in the summation with a function $y_{\mu}(t) = t/\theta_{\mu}$ in which θ_{μ} is extremely small ($\theta_{\mu} \rightarrow 0$).

Substitution of (2) into (1a) and further manipulations lead to the following system of differential equations

$$\ddot{\epsilon}_{\mu} + A_{\mu}(t)\dot{\epsilon}_{\mu} = \frac{\dot{\sigma}}{B_{\mu}(t)} \quad (\mu = 1, \dots N) \dots\dots\dots (3a)$$

$$\dot{\epsilon} = \frac{\dot{\sigma}}{E(t)} + \sum_{\mu=1}^N \dot{\epsilon}_{\mu} \dots\dots\dots (3b)$$

where the dot over a variable denotes the time derivative [for detailed derivation see Bažant (1971, 1975)]. For general functions $y_{\mu}(t)$ one has $A_{\mu}(t) = \dot{y}_{\mu} - \ddot{y}_{\mu}/\dot{y}_{\mu}$ and $B_{\mu}(t) = C_{\mu}/\dot{y}_{\mu}$ which, for the choice $y_{\mu}(t) = t/\theta_{\mu}$, reduce to $A_{\mu}(t) = \text{constant} = 1/\theta_{\mu}$ and $B_{\mu}(t) = \theta_{\mu}C_{\mu}$.

Eqs. (3a) and (3b) turn out to be the governing equations of the Kelvin chain shown in Fig. 1(c), with aging spring moduli $E_{\mu}(t)$ and dashpot viscosities $\eta_{\mu}(t)$ such that $A_{\mu}(t) = (E_{\mu} + \dot{\eta}_{\mu})/\eta_{\mu}$ and $B_{\mu}(t) = \eta_{\mu}$ (an important point for this derivation is that the equation for an aging spring is $\dot{\sigma} = E(t)\dot{\epsilon}$, and not $\sigma = E(t)\epsilon$ as it was assumed or implied in some early models; the latter equation is physically unjustified and violates the second law of thermodynamics [see Bažant (1975, 1982a)]. Equating these expres-

sions to those obtained from the Dirichlet series (2), one obtains $E_\mu(t) = C_\mu - \dot{C}_\mu/\dot{y}_\mu$ and $\eta_\mu(t) = C_\mu/\dot{y}_\mu$. In the particular case of $y_\mu(t) = t/\theta_\mu$, these expressions reduce to $E_\mu(t) = C_\mu - \theta_\mu \dot{C}_\mu$ and $\eta_\mu(t) = \theta_\mu C_\mu$. Note that with these expressions one can always identify the coefficients $E_\mu(t)$ and $\eta_\mu(t)$ of a Kelvin chain equivalent to a given Dirichlet series-type compliance function (2), but not the opposite. Identification of the Dirichlet coefficients, $C_\mu(t)$ and $y_\mu(t)$, from the parameters of the general Kelvin chain, $E_\mu(t)$ and $\eta_\mu(t)$, leads to a nonlinear second-order differential equation that has no closed-form solution except for some particular expressions of the functions $E_\mu(t)$ and $\eta_\mu(t)$.

Two particular cases are of interest for their use later in the paper. First, consider a Kelvin chain with dashpot viscosities $\eta_\mu(t) = \tau_\mu E_\mu(t)$ and general (unspecified) moduli $E_\mu(t)$. In this case, no closed-form solution can be obtained for $C_\mu(t)$ and $y_\mu(t)$ (and therefore, in particular, the solution is not that given by coefficients $C_\mu = E_\mu$ and $y_\mu = t/\tau_\mu$). The second case of interest is the nonaging Kelvin chain with constant moduli E_μ and viscosities $\eta_\mu = \tau_\mu E_\mu$. In contrast to the general formulation with aging, the nonaging chain is fully equivalent to the Dirichlet series compliance function, with the result that $\dot{C}_\mu = E_\mu$ and $\theta_\mu = \tau_\mu$ always (in fact, in this particular case the second-order system (3) can be simplified into a first-order system [see *Mathematical* (1988)]).

In a similar way, in order to convert the integral equation (1b) into a differential equation system, one can introduce for $R(t, t')$ the general Dirichlet series expansion

$$R(t, t') = \sum_{\mu=1}^N E_\mu(t') e^{-[y_\mu(t) - y_\mu(t')]} \dots \dots \dots (4)$$

where $y_\mu(t) =$ monotonically increasing functions of t , which can be conveniently chosen as $y_\mu(t) = t/\tau_\mu$ where $\tau_\mu =$ constants called the relaxation times. Introducing (4) into the corresponding integral equation (1b), one obtains, after some mathematical manipulation

$$\dot{\sigma}_\mu + \dot{y}_\mu(t)\sigma_\mu = E_\mu(t)\dot{\epsilon} \quad (\mu = 1, \dots, N) \dots \dots \dots (5a)$$

$$\sigma = \sum_{\mu=1}^N \sigma_\mu \dots \dots \dots (5b)$$

Eq. (5) turns out to be the governing equations of the aging Maxwell chain [Fig. 1(d)], with aging spring moduli $E_\mu(t)$ and dashpot viscosities $\eta_\mu(t) = E_\mu(t)\dot{y}_\mu(t)$. The inverse relation is $\dot{y}_\mu(t) = E_\mu(t)/\eta_\mu(t)$. Note that, in contrast to what happened with J , in this case there is a direct correspondence in both ways between the coefficients of the Dirichlet series and the Maxwell chain parameters, and for this reason the same functions $E_\mu(t)$ have been directly used for both expressions. For the usual choice $\eta_\mu(t) = \tau_\mu E_\mu(t)$, one has $\dot{y}_\mu(t) = 1/\tau_\mu$, i.e., for a general aging Maxwell chain the coefficients τ_μ are equal to the retardation times of the Dirichlet series (4). This, together with the fact that (5) is a system of first-order differential equations in contrast to (3), which is of second order, makes the formulation of aging viscoelasticity based on the relaxation approach considerably simpler to handle than its equivalent based on the compliance function.

INTEGRAL EQUATION FOR SOLIDIFYING MATERIAL BASED ON MICROCOMPLIANCE FUNCTION $\Phi(t - t')$

The derivation of a constitutive law for the solidifying material in terms of the nonaging compliance function of the basic constituent Φ and the solidified fraction law $v(t)$ was originally presented in Bažant (1977). The same final equations will now be derived by an alternative and simpler procedure.

The basic simplified model of the solidification process is shown in Fig. 2(a). It is assumed that the new layers of material being solidified join the existing ones in a parallel coupling. If the effective volume of solidified constituent at age t is $V(t)$ and the final value reached when all chemical reactions of cement hydration have been completed is $V(\infty)$, the process can be represented by the nondimensional monotonically increasing function $v(t) = V(t)/V(\infty)$, which can be interpreted geometrically as the cross-section area fraction in Fig. 2(a). It is now crucial to note that when a new solidified layer joins the solid microstructure, it must be stress-free (Bažant 1977), while the existing ones will in general carry some stresses. This causes the microscopic stresses s acting on the infinitesimal layers at any time t to be a function of the location of the layer, which will be characterized [same as in Bažant (1977)] by the value of v when the layer solidified at age θ , i.e., $s = s[v(\theta), t]$, as also represented in Fig. 2(a). The aforementioned stress-free initial condition is now represented as $s[v(t), t] = 0$.

Two basic governing equations can be written for the solidification model: (1) The equilibrium equation between the macroscopic stress σ and the stresses at the layers s ; and (2) the constitutive equation for a generic layer:

$$\sigma(t) = \int_{\theta=0}^t s[v(\theta), t] dv(\theta) \dots\dots\dots (6a)$$

$$\varepsilon(t) - \varepsilon(\theta) = \int_{t'=0}^t \Phi(t - t') ds(t') \dots\dots\dots (6b)$$

In the equilibrium equation (6a), the integration variable θ is used to char-

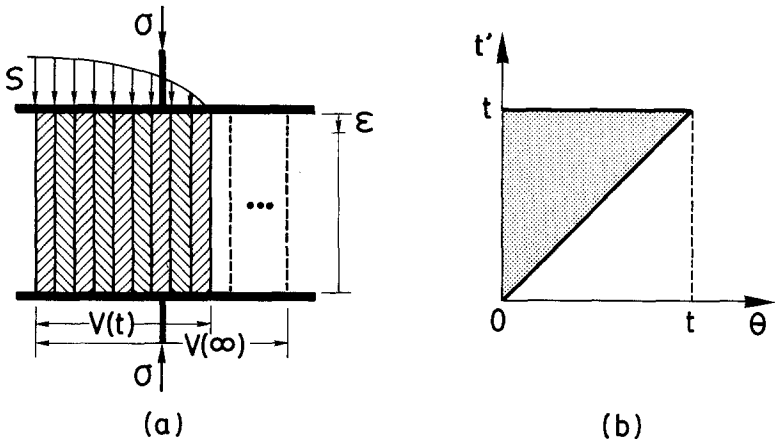

FIG. 2. (a) Solidification Model with Parallel Arrangement of Constituent Layers; (b) Integration Domain in $\theta - t'$ Space

acterize the time at which every infinitesimal layer solidified and therefore the integral extends only over the layers that exist at time t . The constitutive equation (6b) means that only the part of the strain occurring after its solidification (time θ) causes deformation of that particular layer.

Let us now calculate derivatives of (6a) and (6b) with respect to t , taking into account that both the integrand and the integral limits involve t , and that $s[v(t), t] = 0$

$$\dot{\sigma}(t) = \int_{\theta=0}^t \dot{s}[v(\theta), t] dv(\theta) \dots\dots\dots (7a)$$

$$\dot{\epsilon}(t) = \int_{r'=0}^t \dot{\Phi}(t - t') ds(t') + \Phi(0)\dot{s}[v(\theta), t] \dots\dots\dots (7b)$$

where $\dot{s} = \partial s(v, t)/\partial t$, $\dot{\Phi} = \partial \Phi(t - t')/\partial t$, and $\Phi(0)$ has the meaning of the inverse of the elastic modulus of the constituent. Eq. (7b) holds for any value of θ ranging from 0 to t . To eliminate microstresses s from (7a) and (7b), both sides of (7b) can be considered as functions of θ , multiplied by $dv(\theta)$ and integrated with respect to θ from 0 to t :

$$\int_{\theta=0}^t \dot{\epsilon}(t) dv(\theta) = \int_{\theta=0}^t \int_{r'=0}^t \dot{\Phi}(t - t') ds(t') dv(\theta) + \int_{\theta=0}^t \Phi(0)\dot{s}[v(\theta), t] dv(\theta) \dots\dots\dots (8)$$

The terms $\dot{\epsilon}(t)$ on the left-hand side and $\Phi(0)$ on the right-hand side are both independent of θ , and therefore they can be moved in front of the integrals. Also, one can set $ds(t') = s[v(\theta), t'] dt'$. Finally, the limits of the double integral can be changed to make them more convenient; indeed the domain covered ($\theta = 0$ to t and $t' = \theta$ to t), which is represented in Fig. 2(b), can also be covered by the alternative limits $t' = 0$ to t and $\theta = 0$ to t' . Introducing these changes one obtains, after some additional manipulations

$$\dot{\epsilon}(t)v(t) = \int_{r'=0}^t \dot{\Phi}(t - t') \left[\int_{\theta=0}^{t'} s[v(\theta), t'] dv(\theta) \right] dt' + \Phi(0) \left[\int_{\theta=0}^t s[v(\theta), t] dv(\theta) \right] \dots\dots\dots (9)$$

Replacing the two terms in tall brackets, according to (7a), by $\dot{\sigma}(t')$ and $\dot{\sigma}(t)$ respectively, setting $\dot{\sigma}(t') dt' = d\sigma(t')$, and rearranging the terms of the equation, one obtains the final equation

$$\dot{\epsilon}(t) = \frac{1}{v(t)} \left[\Phi(0)\dot{\sigma}(t) + \int_{r'=0}^t \dot{\Phi}(t - t') d\sigma(t') \right] \dots\dots\dots (10)$$

which is the constitutive equation of the aging material based on the compliance function Φ of the nonaging constituent and the aging function $v(t)$, the same as obtained in Bažant (1977). In the same study, the compliance function of the aging material in terms of Φ and $v(t)$ is finally derived by differentiating integral equation (1a) with respect to t and comparing with (10). The final expression is

$$J(t, t') = \frac{\Phi(0)}{v(t')} + \int_{\theta=t'}^t \frac{1}{v(\theta)} \dot{\Phi}(\theta - t') d\theta \dots\dots\dots (11)$$

INTEGRAL EQUATION FOR SOLIDIFYING MATERIAL BASED ON MICRORELAXATION FUNCTION $\Psi(t - t')$

As in the foregoing section, the basic equations are: (1) The equilibrium equation between the macroscopic stress and the microscopic (layer) stresses; and (2) the constitutive equation of a generic layer of nonaging constituent. The equilibrium equation is now also given by (6a), and the constitutive equation based on microrelaxation function Ψ for a layer solidified at time θ now is:

$$s[v(\theta), t] = \int_{t'=0}^t \Psi(t - t') d\varepsilon(t') \dots\dots\dots (12)$$

where the limits of the integral reflect the fact that only the strain that has occurred after the time at which the layer solidified produces stress in that layer. Introducing (12) into (6a), one obtains

$$\sigma(t) = \int_{\theta=0}^t \int_{t'=0}^t \Psi(t - t') d\varepsilon(t') dv(\theta) \dots\dots\dots (13)$$

The limits of the integral can be modified, same as in the integral of (8), to $t' = 0$ to t and $\theta = 0$ to t' . Then, the only term depending on θ is $dv(\theta)$, which can be integrated directly to give $v(t')$. The resulting constitutive relation is:

$$\sigma(t) = \int_{t'=0}^t \Psi(t - t')v(t') d\varepsilon(t') \dots\dots\dots (14)$$

Eq. (14) has been derived following the same methodology as for (10) in the previous section. However, in this case a shorter derivation is also possible, directly from the principle of superposition. For that purpose, consider a load history consisting of strain step $d\varepsilon(t')$ applied at time t' . Because the basic constituent is nonaging, the corresponding stress history at any layer that exists at time t' is $ds(t) = \Psi(t - t') d\varepsilon(t')$. The layers that solidify later than t' do not contribute since the strain is kept constant after t' . Therefore, the overall stress σ at any time $t > t'$ is $d\sigma(t) = \Psi(t - t')v(t') d\varepsilon(t')$. Then, considering the strain history $\varepsilon(t)$ as the sum of infinitely small steps $d\varepsilon(t')$ and applying the principle of superposition, one obtains from this expression directly (14). Comparison of (14) with (1b) gives the result:

$$R(t, t') = v(t')\Psi(t - t') \dots\dots\dots (15)$$

Note now that the macroscopic constitutive equation (10) based on the microcompliance function Φ involves derivatives of the strain and of Φ , and the corresponding compliance function (11) is also given by an integral of derivatives of Φ . On the other hand, the macroscopic constitutive equation (14) based on the microrelaxation function Ψ is expressed directly in terms of σ and Ψ rather than their derivatives, and the corresponding relaxation function (15) is also simpler than its counterpart (11). Also, note that the relaxation function given by (15) is of the "product" type, i.e., a product of two functions: one of the age at loading t' , and the other of load duration

$t - t'$. This convenient format cannot be achieved for the compliance function (11).

The higher degree of complexity of the creep-based expressions stems from the assumption of parallel coupling among the layers of the basic constituent that solidify at different ages [Fig. 2(a)]. The creep formulation based on a compliance function [(1a) or (6a)], represents a summation of various contributions to the creep strain, which is in fact a series coupling hypothesis. This is because the basic stress history that corresponds to the definition of the compliance function (J or Φ) is a stress step. For this type of stress history, the behavior of the parallel solidification model assumed here results in coupling among all the layers that solidified at different times (for constant stress, strain varies in time, causing stresses to appear in new layers and, as the total stress must remain constant, this means a stress reduction in the existing layers). This fact is reflected in the overall governing equations (6a) and (6b), which are coupled and require several steps of mathematical rearrangements to combine properly, and finally give an expression in terms of strain rate rather than strain.

In contrast, when the relaxation function Ψ is used for characterizing the behavior of the basic constituent, the behavior of the layer for the basic history (i.e., the strain step) remains uncoupled. This is the reason that it is possible to formulate the equation directly and that the final expression involves directly the stress, strain, and relaxation functions, instead of their derivatives. Note that a formulation that is simpler for the compliance function than for the relaxation function would result if the constituent layers were assumed to be coupled in series rather than parallel, with all the layers having the same stress and their strains being added. However, that would be physically unreasonable for two reasons: (1) Each layer would be constrained between two solids and would not be in contact with the fluid solution from which the solid constituent precipitates or crystallizes (Bažant 1977); and (2) precipitation of new layers would decrease, rather than increase the macroscopic material stiffness.

RELATIONSHIP BETWEEN CONSTITUTIVE EQUATIONS BASED ON MICROCOMPLIANCE AND MICRORELAXATION FUNCTIONS

In linear viscoelasticity, the expressions based on compliance and relaxation functions are always related to each other in such a way that one expression can be derived from the other and vice versa. In this case, the relation between (10) and (14)—or (11) and (15)—can be easily derived by defining first a new variable ψ such that $\psi = v\dot{\epsilon}$ or $\psi = \int v d\epsilon$. Then, (14) can be written as

$$\sigma(t) = \int_{t'=0}^t \Psi(t - t') d\psi(t') \dots\dots\dots (16)$$

By definition, the compliance and relaxation functions are integral equation kernels inverse to each other, which means that $\psi(t) = \int_{t'=0}^t \Phi(t - t') d\sigma(t')$ or, by replacing $\psi(t)$ by its definition

$$\int_{t'=0}^t v(t') d\epsilon(t') = \int_{t'=0}^t \Phi(t - t') d\sigma(t') \dots\dots\dots (17)$$

This is in fact still another equivalent alternative to the integral constitutive equations (10) and (14). Differentiating this equation with respect to t , we obtain integral equation (10) in an alternative manner.

DIRICHLET SERIES EXPANSION OF MICROCOMPLIANCE $\Phi(t - t')$ AND AGING KELVIN CHAIN

The Dirichlet series expansion of the nonaging microcompliance function and its correspondence with the nonaging Kelvin chain rheologic model were explored in Bažant and Prasanna (1989). In that case, however, the introduction of these convenient concepts was confined to the derivation of an efficient numerical algorithm for solving integral expression (10). Now, it will be shown that this type of expansion and rheologic model can be formulated directly for the aging macroconstitutive relations, furnishing new expressions alternative to (10), with new and interesting properties.

The procedure used is similar to the one described in Bažant (1966) and Bažant and Wu (1974b) for general aging materials. To apply that procedure, it is advantageous to consider first the following simple expression for the compliance function of the constituent:

$$\Phi(t - t') = \frac{1}{E} [1 - e^{-(t-t')/\tau}] \dots\dots\dots (18)$$

which, for constant E , is characteristic of a (nonaging) Kelvin unit with spring modulus E and constant dashpot viscosity $\eta = \tau E$. Differentiating (18) with respect to time t and introducing it into (10) gives:

$$\dot{\epsilon}v = \frac{1}{\tau E} \int_{t'=0}^t e^{-(t-t')/\tau} d\sigma(t') \dots\dots\dots (19)$$

This integral equation can be converted into a second-order differential equation. To do that, first (19) is differentiated with respect to t , taking into account that both the integrand and the upper limit of the integral involve t :

$$\ddot{\epsilon}v + \dot{\epsilon}\dot{v} = -\frac{1}{\tau^2 E} \int_{t'=0}^t e^{-(t-t')/\tau} d\sigma(t') + \frac{\dot{\sigma}}{\tau E} \dots\dots\dots (20)$$

Then, (19) is multiplied by $1/\tau$ and added to (20). The result is that the integrals cancel out and, after regrouping the terms, the following differential equation ensues:

$$\ddot{\epsilon} + \left[\frac{1}{\tau} + \frac{\dot{v}(t)}{v(t)} \right] \dot{\epsilon} = \frac{\dot{\sigma}}{\tau E v(t)} \dots\dots\dots (21)$$

This equation turns out to be the same as the equation for a Kelvin unit with aging modulus $E(t) = v(t)E$ (Bažant 1966).

To generalize this conclusion, consider now the Dirichlet series expansion of $\Phi(t - t')$ given by the expression:

$$\Phi(t - t') = \frac{1}{E} + \sum_{\mu=1}^N \frac{1}{E_{\mu}} [1 - e^{-(t-t')/\tau_{\mu}}] \dots\dots\dots (22)$$

which corresponds to a Kelvin chain with nonaging coefficients, and can approximate any realistic nonaging compliance function with any desired accuracy. By substituting the derivative of (22) with respect to t into (10) and moving the summation and the constant E_{μ} in front of the integral, one obtains

$$\dot{\epsilon}(t) = \frac{1}{v(t)} \left[\frac{\dot{\sigma}}{E} + \sum_{\mu=1}^N \frac{1}{E_{\mu}} \int_{t'=0}^t e^{-(t-t')/\tau_{\mu}} d\sigma(t') \right] \dots \dots \dots (23)$$

Now, one can consider a new set of variables ϵ_{μ} ($\mu = 0, 1, \dots, N$), defined as:

$$\dot{\epsilon}_0(t) = \frac{\dot{\sigma}}{Ev(t)} \dots \dots \dots (24a)$$

$$\dot{\epsilon}_{\mu}(t) = \frac{1}{v(t)} \int_{t'=0}^t \frac{1}{E_{\mu}} e^{-(t-t')/\tau_{\mu}} d\sigma(t') \quad (\mu = 1, \dots, N) \dots \dots \dots (24b)$$

ϵ_{μ} represent what is known as internal variables. Each of the equations given by (24b) can be converted into a differential equation in the same way as done for (19), and the following final system is obtained:

$$\ddot{\epsilon}_{\mu} + \left[\frac{1}{\tau_{\mu}} + \frac{\dot{v}(t)}{v(t)} \right] \dot{\epsilon}_{\mu} = \frac{\dot{\sigma}}{\tau_{\mu} E_{\mu} v(t)} \quad (\mu = 1, \dots, N) \dots \dots \dots (25a)$$

$$\dot{\epsilon} = \frac{\dot{\sigma}}{Ev(t)} + \sum_{\mu=1}^N \dot{\epsilon}_{\mu} \dots \dots \dots (25b)$$

This system turns out to be equivalent to the governing equations of the aging Kelvin chain shown in Fig. 1(c) [described by (3) with $A_{\mu}(t) = (E_{\mu} + \dot{\eta}_{\mu})/\eta_{\mu}$ and $B_{\mu}(t) = \eta_{\mu}$] with aging spring moduli $E_{\mu}(t) = v(t)E_{\mu}$ and dashpot viscosities $\eta_{\mu}(t) = \tau_{\mu}E_{\mu}(t)$. Thus we have proven that the parallel solidification model with a nonaging Kelvin chain model for the basic constituent is equivalent to an aging Kelvin chain in which all the moduli vary proportionally to the same function $v(t)$.

The equivalent compliance function of the resulting aging material can finally be derived in terms of the nonaging parameters E_{μ} , τ_{μ} , and aging function $v(t)$. Differentiating (22) and introducing it into (11), one obtains

$$J(t, t') = \frac{1}{Ev(t')} + \sum_{\mu=1}^N \frac{1}{E_{\mu}\tau_{\mu}} \int_{\theta=t'}^t \frac{1}{v(\theta)} e^{-(t-\theta)/\tau_{\mu}} d\theta \dots \dots \dots (26)$$

Thanks to the equivalence enunciated before, this is also the compliance function that corresponds to a Kelvin chain model with aging coefficients $E_{\mu}(t) = E_{\mu}v(t)$ and $\eta_{\mu}(t) = \tau_{\mu}E_{\mu}(t)$. This compliance function still retains an integral, which can be eliminated for specific expressions of $v(t)$ (provided a closed-form integration is possible for the resulting expression).

DIRICHLET SERIES EXPANSION OF MICRORELAXATION FUNCTION $\Psi(t - t')$ AND AGING MAXWELL CHAIN

Applying again the procedure described by Bažant and Wu (1974b), this time for the microrelaxation function, we first consider the single-term exponential expression

$$\Psi(t - t') = Ee^{-(t-t')/\tau} \dots \dots \dots (27)$$

which corresponds to the behavior of a single nonaging Maxwell unit with constant spring modulus E and constant dashpot viscosity $\eta = \tau E$. Introducing (27) into (14), one obtains:

$$\sigma(t) = E \int_{t'=0}^t e^{-(t-t')/\tau} v(t') d\varepsilon(t') \dots\dots\dots (28)$$

This integral equation can be converted into a first-order differential equation. To do that, first one differentiates (28) with respect to t , taking into account that both the integrand and the upper limit of the integral involve t :

$$\dot{\sigma} = -\frac{E}{\tau} \int_{t'=0}^t e^{-(t-t')/\tau} v(t') d\sigma(t') + E v(t) \dot{\varepsilon} \dots\dots\dots (29)$$

Then, (28) is multiplied by $1/\tau$ and added to (29). The integrals cancel out and, after regrouping the terms, the following differential equation results:

$$\dot{\sigma} + \frac{\sigma}{\tau} = E v(t) \dot{\varepsilon} \dots\dots\dots (30)$$

This equation turns out to be the same as the governing equation of a Maxwell unit with aging modulus $E(t) = v(t)E$. Note that, even with aging, (30) is of first order, while (21) was of second order.

To generalize, consider now the Dirichlet series expansion of $\Psi(t - t')$ given by the expression:

$$\Psi(t - t') = \sum_{\mu=1}^N E_{\mu} e^{-(t-t')/\tau_{\mu}} \dots\dots\dots (31)$$

which corresponds to a Maxwell chain with nonaging coefficients and can approximate any realistic $\Psi(t - t')$ with any desired accuracy. By substituting (31) into (14) and moving the summation and the constant E_{μ} in front of the integral, one obtains

$$\sigma(t) = \sum_{\mu=1}^N E_{\mu} \int_{t'=0}^t e^{-(t-t')/\tau_{\mu}} v(t') d\varepsilon(t') \dots\dots\dots (32)$$

Now, one may consider a new set of variables σ_{μ} ($\mu = 1, \dots, N$) representing internal variables defined as:

$$\sigma_{\mu}(t) = E_{\mu} \int_{t'=0}^t e^{-(t-t')/\tau_{\mu}} v(t') d\varepsilon(t') \quad (\mu = 1, \dots, N) \dots\dots\dots (33)$$

Each of these equations can be converted into a differential equation in the same way as done for (28), and the following final system ensues:

$$\dot{\sigma}_{\mu} + \frac{\sigma_{\mu}}{\tau_{\mu}} = E_{\mu} v(t) \dot{\varepsilon} \quad (\mu = 1, \dots, N) \dots\dots\dots (34a)$$

$$\sigma = \sum_{\mu=1}^N \sigma_{\mu} \dots\dots\dots (34b)$$

Similarly as before, the system (34) turns out to be equivalent to the governing equations of the aging Maxwell chain represented in Fig. 1(d) [(5) with $y_{\mu}(t) = t/\tau_{\mu}$], with aging spring moduli $E_{\mu}(t) = v(t)E_{\mu}$ and dashpot viscosities $\eta_{\mu}(t) = \tau_{\mu}E_{\mu}(t)$. Thus, it is proven that the parallel solidification model with a nonaging Maxwell chain for the basic constituent is equivalent

to an aging Maxwell chain model in which all the moduli vary proportionally to the same function $v(t)$.

One can finally obtain the expression of the overall equivalent relaxation function for the aging material, in terms of the nonaging parameters of the constituent and the aging function. This is done by direct substitution of (31) into (15), which leads to

$$R(t, t') = v(t') \sum_{\mu=1}^N E_{\mu} e^{-(t-t')/\tau_{\mu}} \dots\dots\dots (35a)$$

or

$$R(t, t') = E(t') \sum_{\mu=1}^N \alpha_{\mu} e^{-(t-t')/\tau_{\mu}} \dots\dots\dots (35b)$$

in which $E(t') = v(t')E =$ macroscopic elastic modulus at age t' , with $E = \sum_{\mu=1}^N E_{\mu} =$ macroscopic modulus at $t = \infty$, and $\alpha_{\mu} = E_{\mu}/E$.

IMPLICATIONS OF PROPORTIONALITY OF AGING LAWS OF ALL CHAIN MODULI

The fact that all the spring moduli (of the Kelvin or Maxwell chains equivalent to the solidification model) vary proportionally has some interesting implications. With respect to the general case where each modulus can have an independent variation, a proportional evolution for all the moduli means a significant restriction reducing the number of degrees of freedom available for matching experimental data. However, it has been pointed out that for the general unrestricted aging Kelvin or Maxwell models, there are endemic difficulties in the identification of material parameters that can be explained only by an excessive number of degrees of freedom in the model. Therefore, it appears that this restriction (which is not arbitrary, but has been obtained as a result of the physical formulation of the solidification process) can have a beneficial effect, facilitating the attainment of uniqueness of identification of the moduli and avoiding their undesirable negative values.

Another interesting implication of a single aging function $v(t)$ for all chain moduli can be derived with respect to the controversial topic of the divergence of the creep curves for different ages at loading (formally defined to occur when $\partial^2 J/\partial t \partial t' < 0$ [see *Mathematical* (1988)]). It is appropriate to note that the use of creep models exhibiting divergence of the creep curves for different t' , together with the application of the principle of superposition, can lead to apparently misleading results, as for instance a reversal of the creep strain recovery upon unloading. This does not, however, necessarily imply the compliance function exhibiting this kind of divergence to be wrong. In fact, some of the experiments for concrete (albeit not many) did exhibit divergence, and it seems also clear that the problem of creep recovery reversal obtained with a model exhibiting divergence arises mainly from the application of the principle of superposition, which in reality is not fully satisfied upon unloading [see a detailed discussion on pages 152–154 of *Mathematical* (1988)]. However, because the principle of superposition, despite this evidence, implies linearity overall (and is assumed applicable in all the design codes and most of the existing computer programs), it is important to know whether a given creep model can or cannot exhibit the divergence, and it is preferable to avoid it.

For the Kelvin chain, one can demonstrate (*Mathematical* 1988) that, for positive and monotonically increasing functions $y_\mu(t)$, the nondivergence condition $\partial^2 J / \partial t \partial t' > 0$ is satisfied if all moduli $E_\mu(t)$ are always positive. In the general case of a Kelvin chain with independently aging parameters, this cannot be guaranteed since the minimization process necessary for matching experimental data can lead (due to the ill-posedness of the moduli identification problem) to transiently negative values of one or more moduli. However, when linked through a common positive and monotonically increasing aging law $v(t)$, the problem reduces to a set of constants E_μ , which can certainly be guaranteed to be always positive.

For the Maxwell chain and relaxation function, no relation has been derived for linking their coefficients to the occurrence of creep divergence, though it appears a logical assumption that it is also related to negative values of the moduli. Alternatively, one can in this case define the concept of relaxation divergence, which would occur when $\partial^2 R / \partial t \partial t' > 0$. Geometrically, this would mean that the curve for loading at $t' + dt'$ would have at time t a downward slope of a lesser magnitude than the curve for loading at t' at the current time t , which is opposite to the normal behavior represented in Fig. 1(b). If this occurs, the response of the model to a strain history consisting of application and subsequent removal of the same strain step would exhibit a reversal of the relaxation recovery curve, as illustrated in Fig. 3. Although not as commonly considered as the creep recovery case, this would also very clearly be an anomalous response that one could reasonably expect to be related to the occurrence of creep divergence (although this relationship has not been proven so far). Differentiating (4) (with $y_\mu = t/\tau_\mu$) with respect to t and t' , one obtains

$$\frac{\partial^2 R(t, t')}{\partial t \partial t'} = - \sum_{\mu=1}^N \left[\frac{E_\mu(t)}{\tau_\mu^2} + \frac{\dot{E}_\mu(t)}{\tau_\mu} \right] e^{-(t-t')/\tau_\mu} \dots \dots \dots (36)$$

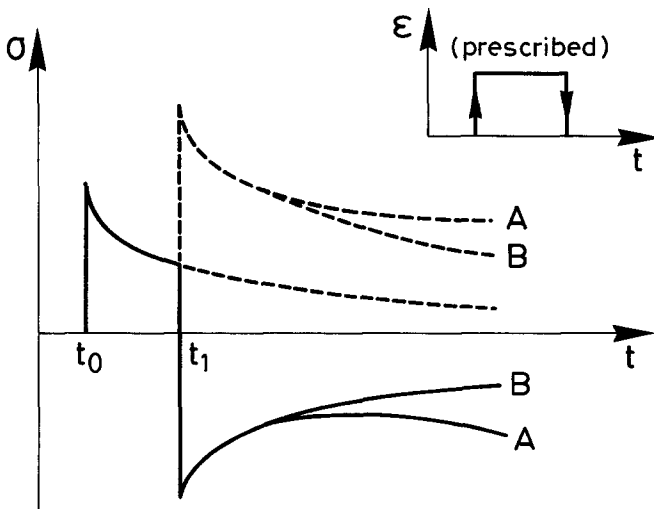

FIG. 3. Relaxation after Application and Removal of Strain Step, with (Curves A) or Without (Curves B) Relaxation Reversal

This expression is guaranteed to be negative if all the moduli and their derivatives are positive. Same as what happened with the Kelvin chain, this is not necessarily satisfied by the general Maxwell chain with independent aging moduli, but it can always be fulfilled by the Maxwell chain resulting from the solidification model, in which all the moduli grow proportionally to one function $v(t)$.

MULTIPLE SOLIDIFICATION PROCESSES AND GENERAL KELVIN CHAIN

The hypothesis that there is only a single solidification process characterized by a single function $v(t)$ is no doubt a simplification. In fact, long duration creep data for concrete involving concrete loaded at young ages cannot be successfully fitted by solidification theory with a single function $v(t)$ [Bažant and Prasannan (1989b)]. Rather, it is necessary to add to the strain associated with $v(t)$ another strain component that corresponds to an aging dashpot of viscosity $\eta(t) = \eta_0 v_N(t)$ where $\eta_0 = \text{constant}$ and $v_N(t)$ is a function different from $v(t)$ (a dashpot can be regarded as the limit case of a Kelvin unit for $E_\mu \rightarrow 0$).

If there are several distinct solidification processes $v_\mu(t)$ in the microstructure of a porous solidifying material such as portland cement or concrete, it does make sense to generalize the foregoing analysis. The reason for multiple solidification processes is as follows. Because mass transport in smaller pores is slower and takes longer to reach thermodynamic equilibrium, function $v_\mu(t)$ for small pores (the gel pores in hardened cement paste) should rise slowly and take a long time to reach a final asymptotic value, while function $v_\mu(t)$ for large pores (e.g., the capillary pores in hardened cement paste) should initially rise rapidly and attain a final asymptotic value soon. Let us assume that the pores in which solidification occurs may be grouped into ensembles of like sizes, each characterized by its volume growth function $v_\mu(t)$. Let $\epsilon_\mu(t)$ be the strain associated with $v_\mu(t)$, and assume that the stress in the ensemble of pores of each size is the same and equal to σ . This means the ensembles are assumed to be coupled in series. By the same argument as that which led to (10) and (14), for each $v_\mu(t)$ we have similar integral equations involving the microcompliance Φ_μ , microrelaxation Ψ_μ and strain ϵ_μ instead of Φ , Ψ , and ϵ . In particular, by considering (10) for each ensemble and the series-coupling hypothesis, one obtains the system:

$$\dot{\epsilon}(t) = \sum_{\mu=1}^N \dot{\epsilon}_\mu(t) \dots\dots\dots (37a)$$

$$\dot{\epsilon}_\mu(t) = \frac{1}{v_\mu(t)} \left[\Phi_\mu(0)\dot{\sigma}(t) + \int_{t'=0}^t \dot{\Phi}_\mu(t - t') d\sigma(t') \right] \dots\dots\dots (37b)$$

Due to similarity with (10), and assuming for $\Phi_\mu(t - t')$ a one-term exponential expression similar to (18), the calculation that has led from (18) to (21) could now be repeated, replacing $v(t)$, E , and τ with $v_\mu(t)$, E_μ , and τ_μ respectively. The result is a general Kelvin chain governed by the system of equations:

$$\ddot{\epsilon}_\mu + \left(\frac{1}{\tau_\mu} + \frac{\dot{v}_\mu(t)}{v_\mu(t)} \right) \dot{\epsilon}_\mu = \frac{\dot{\sigma}}{\tau_\mu E_\mu v_\mu(t)} \quad (\mu = 1, \dots, N) \dots\dots\dots (38a)$$

$$\dot{\epsilon} = \frac{\dot{\sigma}}{E v_0(t)} + \sum_{\mu=1}^N \dot{\epsilon}_{\mu} \dots\dots\dots (38b)$$

Setting $E_{\mu} v_{\mu}(t) = E'_{\mu}(t) =$ variable spring moduli, we have obtained an equation system identical to that presented before for the general aging Kelvin chain.

If, in the foregoing argument, the ensembles of like-size pores are alternatively assumed to be coupled in parallel, the generalized aging Maxwell chain results.

It is, however, most unlikely that the completely general formulation will ever be needed in practice, or even be appropriate. One reason is that, as already indicated, in the case of a fully general aging Kelvin or Maxwell chain, very different sets of $E_{\mu}(t)$ can approximate a given compliance or relaxation function almost equally well, and the problem of material parameter identification is ill posed, i.e., has too many degrees of freedom. Based on the previous analysis of test results (Bažant and Prasannan 1989b), it appears that two functions $v_{\mu}(t)$ will suffice. In those analyses, it was found that virtually all the existing creep data for concrete can be fitted quite well by using a compliance function that corresponds to a Kelvin chain in which one and the same function $v(t)$ is common to Kelvin units $\mu = 1, \dots, N - 1$, and only the last unit has a different function $v_N(t)$. This last unit is degenerated to a dashpot of aging viscosity governed by $v_N(t)$, which means that $E_N = 0$, and thus all the spring moduli $E_{\mu}(t)$ still vary proportionally to one function $v(t)$ even if a second function $v_N(t)$ operates (the absence of creep divergence thus remains guaranteed). If more than two functions $v_{\mu}(t)$ or nonzero E_N would ever have to be considered, they would have to be determined by some separate considerations (micromechanical analysis of the solidification process) in order to avoid ill-posedness of the problem of identification of the material parameters from creep test data.

CONCLUSIONS

1. The formulation of an aging material in terms of the relaxation function Ψ of the nonaging constituent and variable volume fraction $v(t)$ of the solidified constituent yields a simple integral expression involving Ψ and $v(t)$ that defines the state variable (the stress), whereas the previous formulation in terms of the compliance function Φ of the nonaging constituent yields an integral expression that defines the rate of the state variable (the strain).

2. The Dirichlet series expression with constant coefficients is used not only for Φ as before, but also for Ψ . This makes it possible to convert the integral constitutive equation based on either Φ or Ψ to a system of linear differential equations, much more convenient to solve numerically. The resulting equations are equivalent to the equations governing the aging Kelvin (for Φ) and Maxwell (for Ψ) chains in which the spring moduli all increase proportionally to one function $v(t)$.

3. This constraint on the evolution of the moduli $E_{\mu}(t)$ has the beneficial effect of eliminating the mathematical difficulties due to ill-posedness of the problem of moduli identification usual in general aging Kelvin and Maxwell chains. It also ensures positiveness of all moduli and nondivergence of the creep curves for the Kelvin chain and of the relaxation curves for the Maxwell chain.

4. As a result of the present new formulation, the solidification model, initially developed independently of preceding theories (Bažant 1977; Bažant 1979; Bažant and Prasannan 1989), now becomes equivalent to the well-known rheologic models with aging coefficients. This equivalence provides new insight and clarifies at the same time both approaches. For the solidification model, the equivalence demonstrated here helps to broaden its applicability and understand its nature, and the model itself can be considered as a micromechanical argument giving support to the Kelvin or Maxwell chain with aging spring moduli.

5. The solidification model can be generalized by considering multiple solidification processes represented by multiple aging functions v_{μ} . The resulting equations turn out to be equivalent to the general aging Kelvin or Maxwell chains. However, based on the previous finding that all the existing creep data for concrete can be fitted closely assuming: (1) A single solidification process, characterized by a single volume growth function $v(t)$; and (2) an additional viscous strain described by an aging dashpot, it is shown that, even with two aging functions, all the spring moduli of a Kelvin chain may still be assumed to have the same growth law, i.e., grow proportionally to a single $v(t)$, and therefore the formulation still exhibits all the convenient features mentioned before.

ACKNOWLEDGMENTS

Partial support under NSF grant MSS-8815166 to Northwestern University and supplementary support for the solidification modeling from the Center for Advanced Cement-Based Materials at Northwestern University are gratefully acknowledged. The first writer thanks for financial support received under a fellowship from CIRIT (Generalitat de Catalunya, Barcelona, Spain) for his stay at Northwestern University. Partial support from the CICYT (Madrid, Spain) under research projects PB87-0861 and PA90-0598 is also gratefully acknowledged.

APPENDIX. REFERENCES

- Arutyunian, N. K. (1952). *Some problems in the theory of creep*. Tehteorizdat, Moscow, Russia.
- Bažant, Z. P. (1966). "Phenomenological theories for creep of concrete based on rheological models." *Acta Technica ČSAV*, Prague, Czechoslovakia, 11, 82–109.
- Bažant, Z. P. (1971). "Numerically stable algorithm with increasing time steps for integral-type aging creep." *Proc. 1st Int. Conf. on Struct. Mech. in Reactor Tech.*, 3, Paper H2/3.
- Bažant, Z. P. (1975). "Theory of creep and shrinkage of concrete structures: a précis of recent developments." *Mech. Today*, 2, 1–93.
- Bažant, Z. P. (1977). "Viscoelasticity of solidifying porous material-concrete." *J. Engrg. Mech.*, ASCE, 103(6), 1049–1067.
- Bažant, Z. P. (1979). "Thermodynamics of solidifying or melting viscoelastic material." *J. Engrg. Mech.*, ASCE, 105(6), 933–952.
- Bažant, Z. P. (1982a). "Input of creep and shrinkage characteristics for a structural analysis program." *Mater. Struct.*, Paris, France, 15(88), 283–290.
- Bažant, Z. P. (1982b). "Mathematical models for creep and shrinkage of concrete." *Creep and shrinkage in concrete structures*, Z. P. Bažant and F. H. Wittmann, eds., John Wiley and Sons, New York, N.Y., 163–256.
- Bažant, Z. P., and Prasannan, S. (1989a). "Solidification theory for concrete creep. I: Formulation." *J. Engrg. Mech.*, ASCE, 115(8), 1691–1725.

- Bažant, Z. P., and Prasannan, S. (1989b). "Solidification theory for concrete creep. II: Verification and application." *J. Engrg. Mech.*, ASCE, 115(8).
- Bažant, Z. P., and Wu, S. T. (1973). "Dirichlet series creep function for aging concrete." *J. Engrg. Mech. Div.*, ASCE, 99(2), 367–387.
- Bažant, Z. P., and Wu, S. T. (1974a). "Rate type creep law of aging concrete based on the Maxwell chain." *Mater. Struct.*, Paris, France, 7(37), 45–60.
- Bažant, Z. P., and Wu, S. T. (1974b). "Thermoviscoelasticity of aging concrete." *J. Engrg. Mech. Div.*, ASCE, 100(3), 575–597.
- Kabir, A. F., and Scordelis, A. C. (1979). "Analysis of RC shells for time-dependent effects." *IASS Bull.*, XXI (69).
- Lánczos, C. (1964). *Applied analysis*, Prentice-Hall, Englewood Cliffs, N.J., 272–280.
- Maslov, G. N. (1940). "Thermal stress states in concrete masses, with account of concrete creep." *Izvestia Naucho-Issledovatel'skogo Instituta Gidrotechniki, Gosenergoizdat*, 28, 175–188 (in Russian).
- Mathematical modeling of creep and shrinkage of concrete*. (1988). Z. P. Bažant, ed., John Wiley, New York, N.Y.
- McHenry, D. (1943). "A new aspect of creep in concrete and its application to design." *ASTM, Proc.*, 43, 1069–1086.
- Mukaddam, M. A., and Bresler, B. (1972). "Behavior of concrete under variable temperature and loading." *Concrete for nuclear reactors, ACI S.P.-34*, Detroit, Mich., 771–797.
- Roscoe, R. (1950). "Mechanical models for the representation of viscoelastic properties." *British J. App. Physics*, 1, 171–173.
- Taylor, R. L., Pister, K. S., and Goudreau, G. L. (1970). "Thermomechanical analysis of viscoelastic solids." *Int. J. Numer. Methods Eng.*, 2, 45–60.
- Zienkiewicz, O. C., Watson, M., and King, I. P. (1968). "A numerical method of viscoelastic stress analysis." *Int. J. Mech. Sci.*, 10, 807–827.